

CJC® Condition Monitoring Unit CMU

Advanced oil sensor system



Product Sheet

APPLICATION

The CJC® Condition Monitoring Unit CMU is an advanced oil sensor system consisting of C.C.JENSEN validated sensors, mounted in connection to a CJC® Offline Oil Filter. The CJC® CMU is part of the CJC® Sensor Package Program also consisting of the CJC® Oil Contamination Monitor OCM15. See Product Sheet for the CJC® OCM15 for more information (PSMO4005-UK).

The CJC® CMU is available as retrofit on an existing CJC® Offline Oil Filter or as an integral part of a new CJC® Offline Oil Filter.

The CJC® CMU sensor data can be extracted locally through different protocol options or send to CJC® Cloud (as part of a CJC® T²render solution) or both, see figure 2, on page 2. Please refer to the CJC® T²render Solution Product Sheet. (PSMO4008-UK).

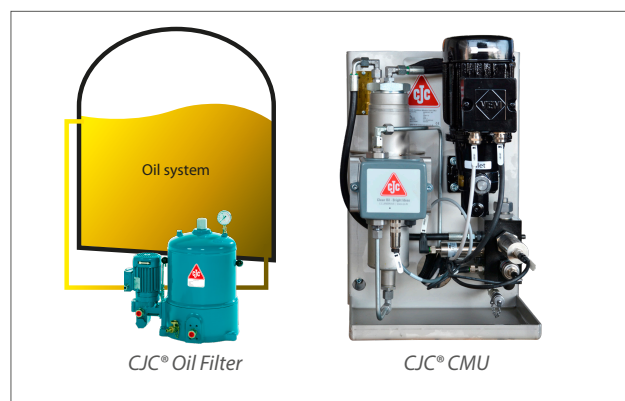

Figure 1:
CJC® Condition Monitoring Unit, CMU in an oil system

BENEFITS

The CJC® CMU is easy to retrofit on a CJC® Offline Oil Filter and can be configured to fit individual needs for oil sensing.

The sensors are thoroughly tested and validated to provide reliable oil condition data.

The CJC® CMU gives direct access to live data and can be used for:

- Condition-based oil sampling which reduces cost for oil sampling
- Optimized operation of the CJC® Offline Oil Filter which extends the lifetime of oil and machinery
- Sensor data monitoring and alert messages enabling condition based equipment handling

FUNCTION

The CJC® CMU is to be mounted at the oil system with two hoses to the inlet of the CJC® Offline Oil Filter.

It has a separate oil circulation system driven by a dedicated pump and ensures optimised handling of any air in the system in order to avoid faulty measurements.

The CJC® CMU communication box contains power supply for all sensors, motor protection for the CJC® CMU motor, a data acquisition module to retrieve all the sensor values and an interface to access the data depending on choice of protocol.

FEATURES

All the sensors are optional and the CJC® CMU can therefore be configured to the exact need for oil sensing.

The available sensors for the CJC® CMU is listed in Table 1 below.

TABLE 1: CJC® CMU SENSOR OPTIONS

Features	Condition Monitoring Unit, CMU					External sensors *)		
	OCM Oil Contamination Monitor	OMT Oil Moisture Transmitter	OQM Oil Quality Monitor	PT100 Temp.	PT in Pressure	PT out Pressure	ODM Oil Debris Monitor	Input
Particles 4-250 µm (according to ISO4406)	●							
Oil moisture Level (%RH)		●						
Oil Condition / Oxidation parameters			●					
Oil Temperature (°C)		●	●	●				
Filter inlet pressure (Bar)					●			
Filter outlet pressure (Bar)						●		
Particles 40-1000 µm (Ferrous/non-ferrous)							●	
Offline Oil Filter- and equipment operation (on / off)								●
Equipment load (0-100%)								●

*) Not integrated on the CJC® CMU. The CMU communication box is prepared for the input signals

PSMO4009-UK

24.09.2020

© 2020 C.C.JENSEN A/S

CJC® Condition Monitoring Unit CMU

Advanced oil sensor system



Product Sheet

THE AVAILABLE DATA INTERFACE OPTIONS CAN BE SEEN BELOW:

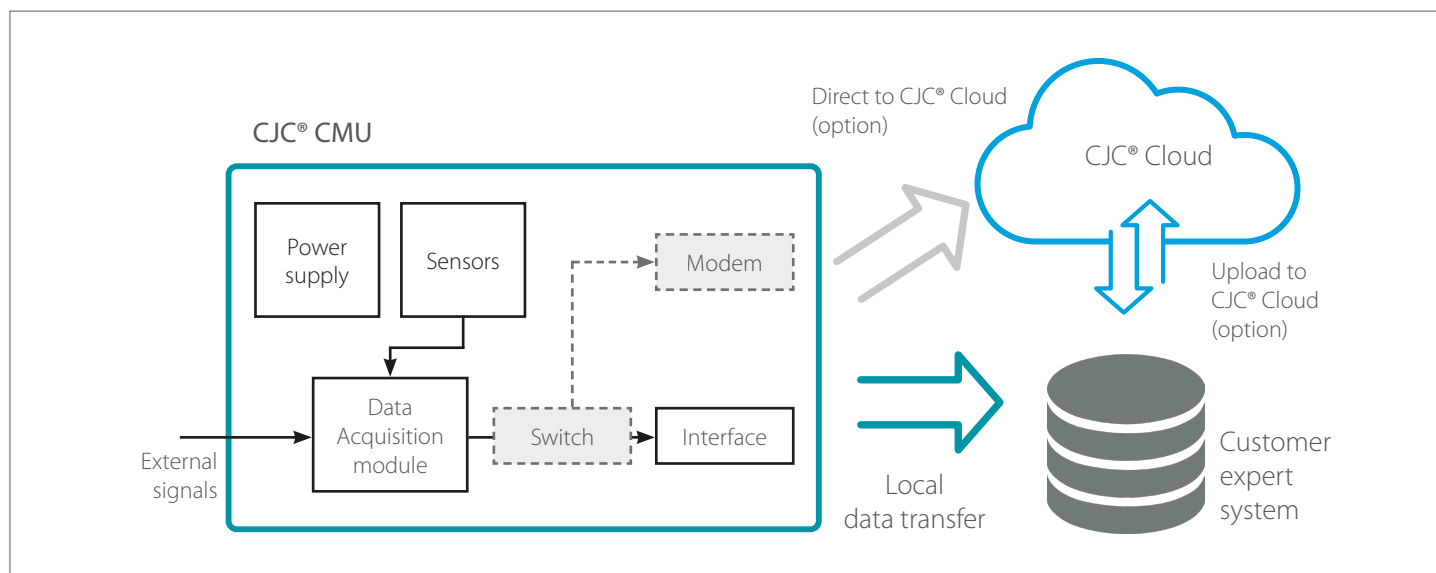

Figure 2:
Data interface options from the CJC® CMU

The CMU can be setup so data can be retrieved locally via:

Ethernet:

- OPC UA
- CAN BUS
- MODBUS TCP
- Profinet
- MQTT

Serial:

- MODBUS RTU
- JSON String
- Profibus

Data connection directly to CJC® Cloud as part of the CJC® T²render Solution can also be established via:

- Ethernet TCP/IP
- WiFi
- Cellular 3G, 4G/LTE

INSTALLATION, OPERATION & MAINTENANCE

C.C.JENSEN supplies a tested CJC® Condition Monitoring Unit CMU fitted to the specified data interface.

Data logging from the CJC® CMU is taken care of by the equipment owner.

In case of retrofit and upon request C.C.JENSEN can supply the needed pipes, fittings and filter modifications and perform the actual installation.

The equipment owner holds all service and maintenance obligations of the CJC® CMU including recalibration of the sensor OCM (2 years). Contact C.C.JENSEN to replace the sensor for recalibration with a corresponding sensor.

HOW TO ORDER

Contact your C.C.JENSEN Sales representative at www.cjc.dk/contact or contact us at

FilterTechnicalSupport@cjc.dk to receive more information.

Article no.	
CMU for retrofit	Different configurations based on article no. FA7617194
CMU as part of an Oil Filter	Contact C.C.JENSEN

Additional support and services, e.g. installation & commissioning, monitoring, report generation and data interpretation can be provided on request.